



Air Curtain Product Guide August 2010 V1.1

In an age of rising energy prices efficient use of resources is essential.

Toshiba in partnership with **Envirotec** (UK leaders in air curtain manufacturing) have launched an energy efficient range of Heat Pump Air Curtains to suit a wide range of environments from offices and retail outlets through to commercial applications.

Heat Pump technology provides an effective method of transferring heat from the atmosphere to where it is most needed, using the least possible power to drive the system. Air Curtain applications with DX heating are easily dealt with using Toshiba Digital Inverter outdoor units.

With Toshiba's unique Twin Rotary Compressor Technology and extremely efficient Hybrid Inverter Compressors, these units make a very cost effective solution providing excellent COP's.

COP—Coefficient of Performance

The coefficient of performance of a system is calculated by the ratio of the power output divided by the power input. The highly efficient systems we are offering would typically have a COP of around 3.5. For every kW of power you put in, you get 3.5kW of power out.

With no additional valves or mechanical components required the installation is very simple. Our new Air Curtain range is easy to install and very simple to use with a variety of options and add-on's also available.

By minimizing heat loss and heat gains through the doorway, our air curtain solutions provide maximum comfort to customers and staff and with a potential reduction in energy consumption of up to 70%, creating minimal impact on the environment.

By utilizing the ES range of air curtains in your premises, open door policy buildings can still create comfortable internal environment in all weather conditions

Peace of mind with a 3 year warranty on all air curtains (please refer to our warranty guideline).



Installation Guidelines and Tips:

- Usually mounted over doorway
- Reduces outside air entering building
- Creates a warm air stream
- Reduces mixing of inside / outside climates
- Energy saving device
- Improves internal environment
- Can be installed in different applications
- Typically 14°C to 16°C temperature difference between room and discharge temperature
- 90 to 92% efficiency, only 8 to 10% of air escapes through the doorway.
- Utilising the latest Inverter Control



Plan view showing air entering building through sides

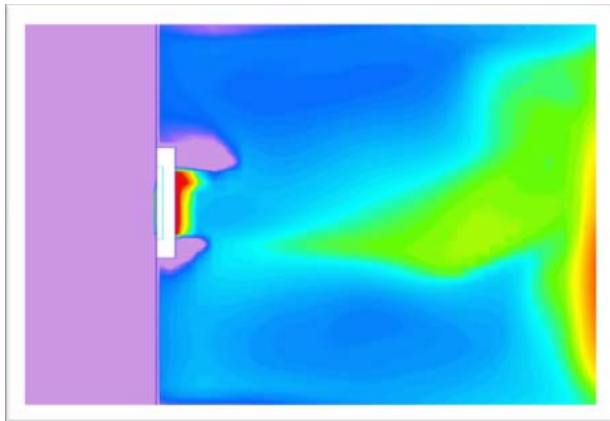

Air curtain not covering full width of doorway

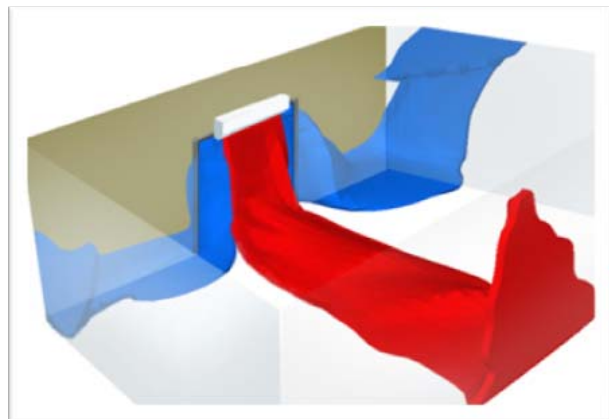

- Cover full width of door opening and where possible overlap by 100mm either side
- Outlet grille as close as possible to top of door
- The discharge outlet should be no more than 400mm from the front of the door
- Install within correct mounting height
- Consider aesthetics / environment
- Units to be mounted horizontally
- Most efficient leaving air velocity 6.5 - 7.5 m/s
- Optimum leaving air temperature 36 - 38°C.
- Achieve laminar flow of air stream
- Designed to work with ambient air temperature of between 16 - 20°C
- Not a barrier, the air stream tempers incoming infiltration
- Can be used throughout summer and winter
- Reduces ingress of flies by up to 85%

Why use an air curtain?

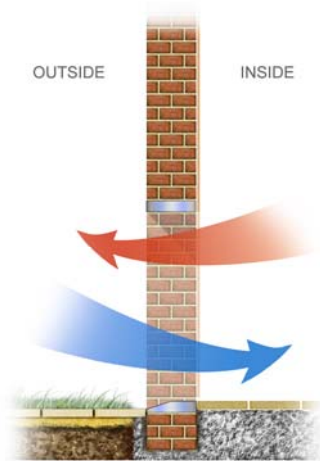

With no air curtain installed in winter...

- Heated air rushes out
- Cold winter air rushes in
- Noticeable drafts near entrance
- Unacceptable building heating cost

With no air curtain installed in summer...

- Air conditioned air rushes out
- Warm, humid air rushes in
- Ingress of insects / pollen
- Increased cooling costs

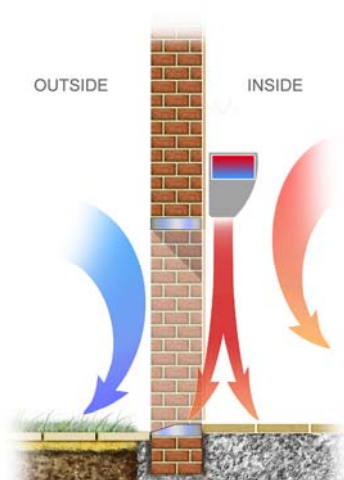
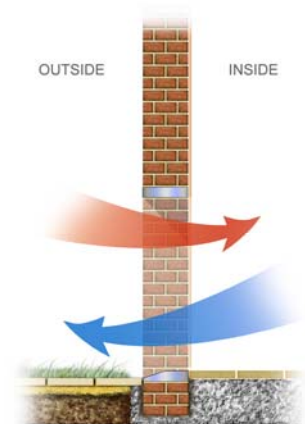

With an air curtain installed...

- Conditioned air contained within building
- Winter cold air kept outside
- Drafts reduced
- Summer warm air kept outside
- Insect ingress reduced
- Reduced heating and cooling costs

Thermal images displaying characteristics:

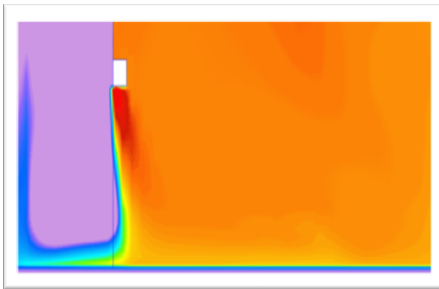

Air Curtain operating

- Building leakage 5m³/h/m²
- Minimal infiltration
- Good climate separation
- Temperature profile even

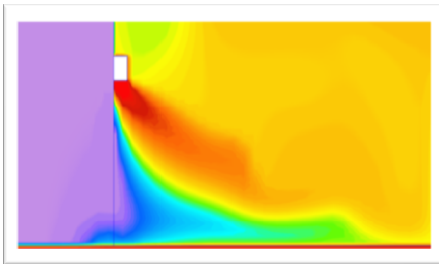

Air Curtain operating

- Building leakage rate increased 20m³/h/m²
- Infiltration is at slightly higher level
- Climates still well separated

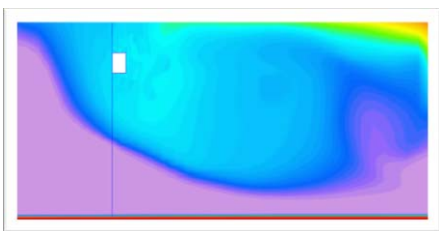

Air Curtain switched off

- Building leakage rate 20m³/h/m²
- Infiltration rate high, cold spots around doorway
- Climates mixing, thus entrance cooling
- Temperature profile very uneven

By utilising the advanced technology of DX type Air Curtains, a saving of up to **70%** power consumption can be realised when comparing to an equivalent more traditional electric air curtain.



DX Air Curtain 'v' Electric Air Curtain

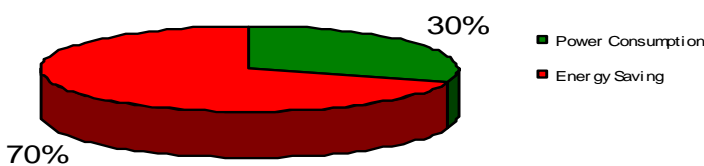



- Toshiba Twin Rotary Compressor Technology
- Outdoor unit 230V, 1 phase supply (3,4 & 6HP)
- Outdoor unit 400V, 3 phase supply (8 & 10HP)
- High efficiency inverter compressor
- Utilises R410A none ozone depleting refrigerant
- Light weight and easy to install
- No additional expansion valves or mechanical equipment

Digital Inverter Heat Pumps

Outdoor Unit	RAV	SM803AT-E	SM1103AT-E	SM1603AT-E	SM2244AT8-E	SM2804AT8-E
Heating Capacity	HP	3	4	6	8	10
Heating Capacity (Range)	kW	8	11.2	16	22.4	28
Power Input, Heating	kW	2.21	3.1	4.43	5.82	7.48
Approximate COP	W/W	3.62	3.61	3.61	3.85	3.61
Airflow	l/s (m3/h)	750 (2700)	1250 (4500)	1717 (6180)	133	133
Sound Pressure Level, Heating	dB(A)	50	54	53	56/57	57/58
Sound Power Level, Heating	dB(A)	67	71	70	72/74	74/75
Pipe Connections, Gas - Liquid	in	5/8 - 3/8	5/8 - 3/8	5/8 - 3/8	1 1/8 - 1/2	1 1/8 - 1/2
Pipe Length, Maximum/Minimum	m	30/5	50/5	50/5	70/5	70/5
Pre Charged Pipe Length	m	20	30	30	30	30
Additional R410a Charge	g/m	40	40	40	80	80
Base Refrigerant Charge	kg	1.7	2.8	3.1	5.9	5.9
Dimensions (h x w x d)	mm	550 x 780 x 290	795 x 900 x 320	1340 x 900 x 320	1540 x 900 x 320	1540 x 900 x 320
Weight	kg	42	77	99	133	133
Maximum Operating Current	A	10.1	14.4	23.9	18	22
Suggested Fuse Size	A	10	20	25	25	25

NOTE : Minimum Air On condition to the coil must be 18°C in heating mode

P 3 phase 400volt

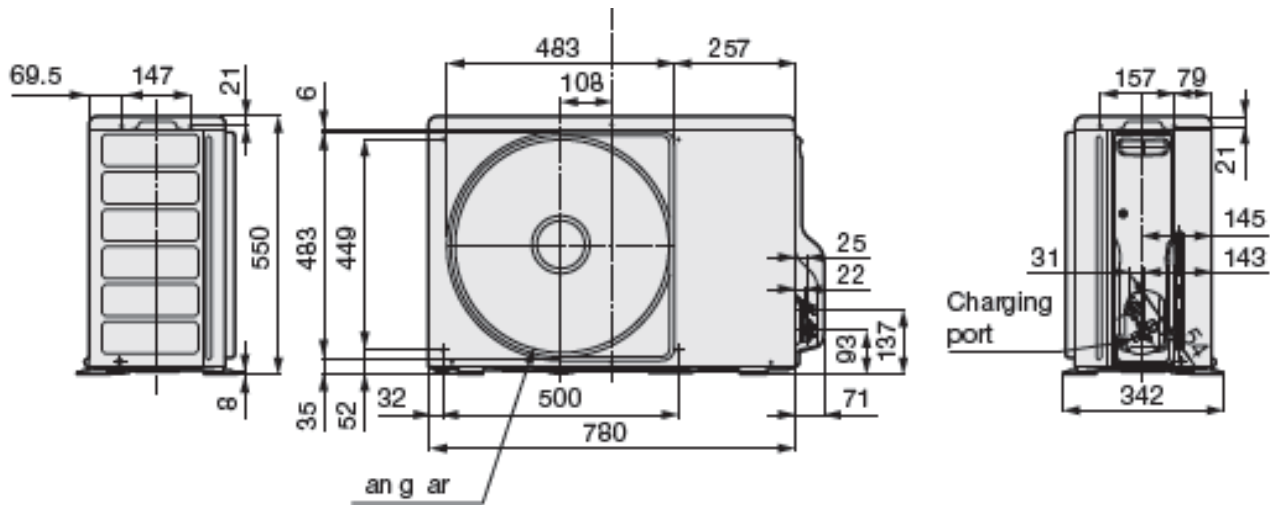

RAV-SM803AT-E

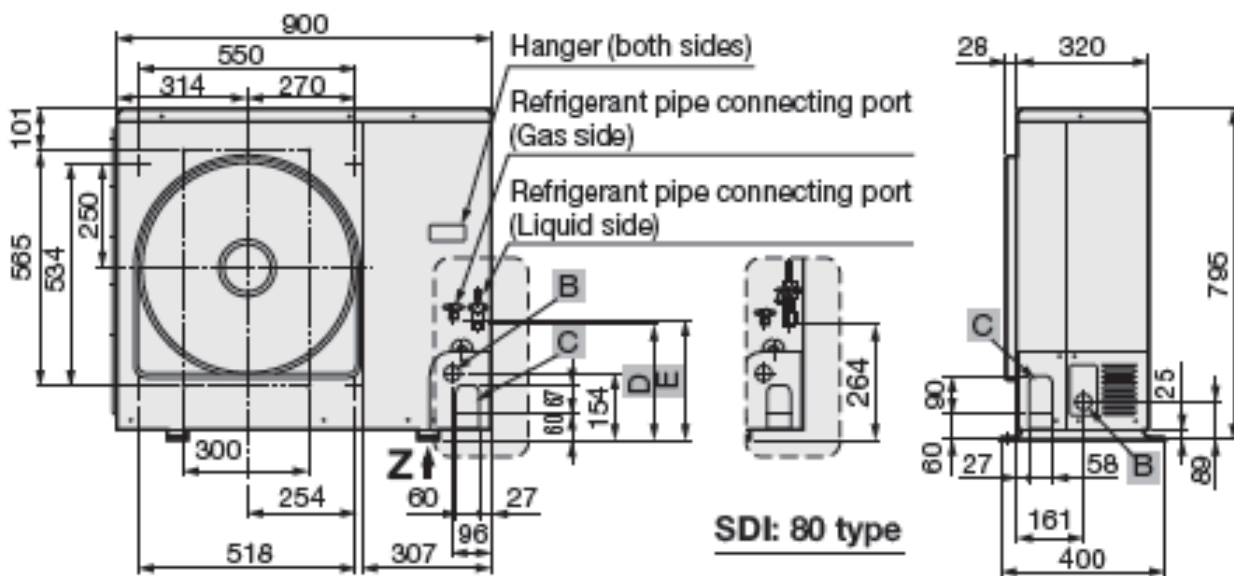

RAV-SM1103AT-E

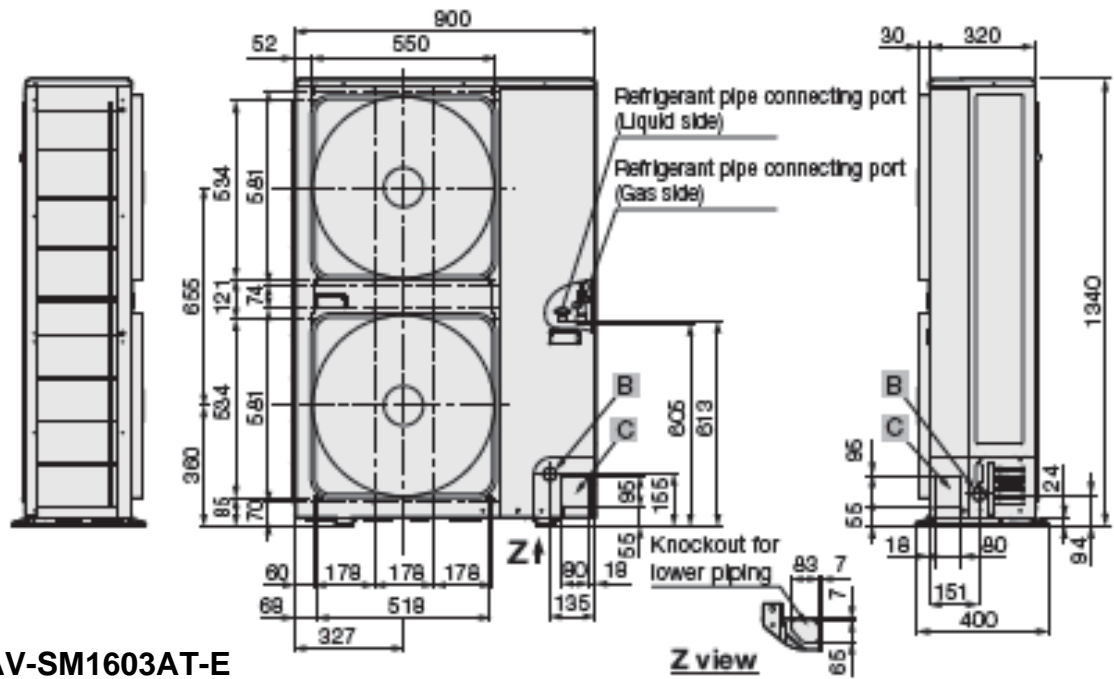

RAV-SM1603AT-E

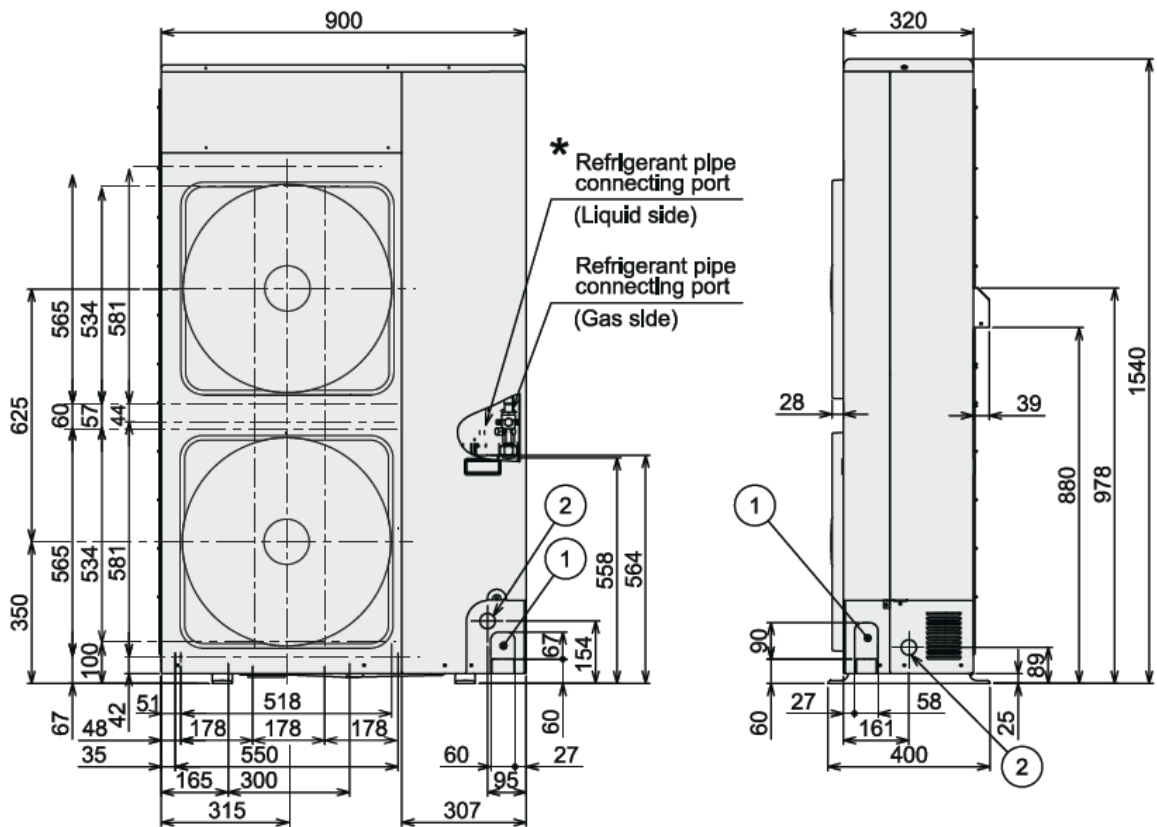

RAV-SM2244AT-E & SM2804AT-E

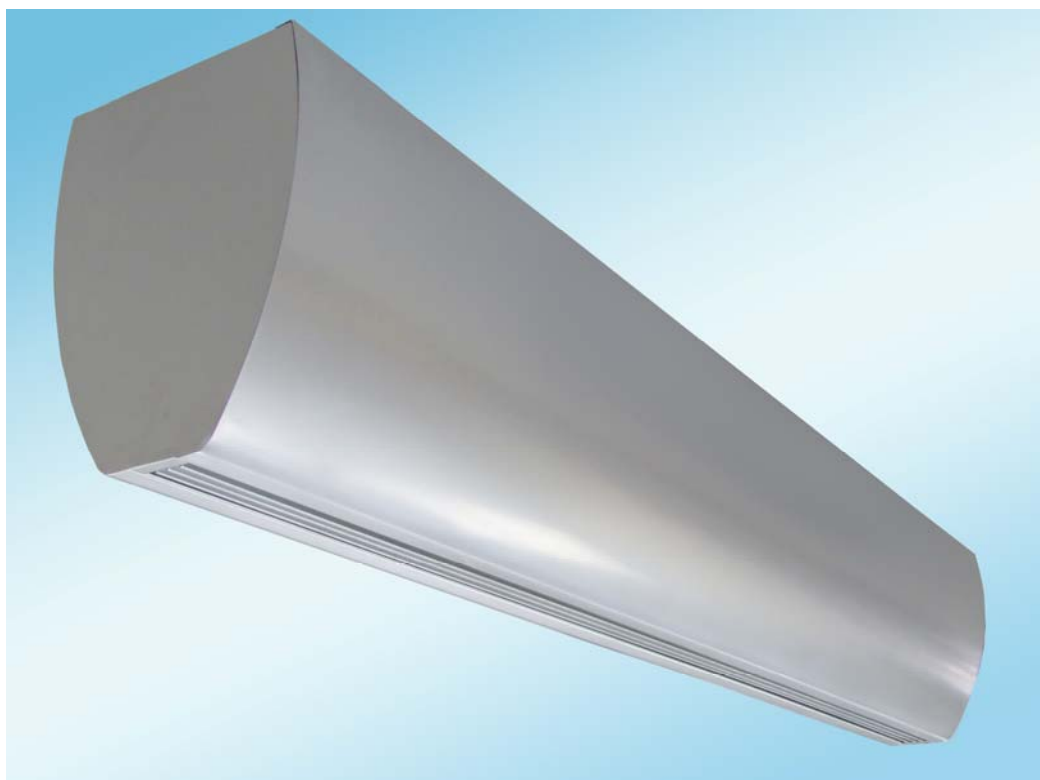

Application: Offices, Retail, Commercial
 Mounting type: On view
 Mounting height: 2200mm to 3000mm
 Mounting options: Hanging via drop rods
 Standard finish: White RAL9010 (others available upon request £poa)
 Connection to: Toshiba Digital Inverter series of condensing units

Type A Curtain

		A-ES10-HP	A-ES15-HP	A-ES20-HP	A-ES25-HP	A-ES30-HP
Mounting Height (Max)	mm	3000	3000	3000	3000	3000
Length	mm	1000	1500	2000	2500	3000
Width x Height	mm	385 x 520	385 x 520	385 x 520	385 x 520	385 x 520
Heat Output (Max)	kW	8	11.2	16	22.4	28
Motor Power	kW	0.16	0.16	0.32	0.32	0.32
Starting Current	A	2	2	4	4	4
Power Supply	230v	1 Phase	1 Phase	1 Phase	1 Phase	1 Phase
Air Volume	m³/s	0.42	0.63	0.84	1.05	1.26
Air Volume	m³/h	1512	2268	3024	3780	4536
Entering Air Temp	°c	18	18	18	18	18
Air Density	kg/m³	1.21	1.21	1.21	1.21	1.21
Temperature Difference	°c	15.7	14.7	15.7	17.6	18.4
Leaving Air Temperature	°c	33.7	32.7	33.7	35.6	36.4
Drop Rod Mounting Plate		Yes	Yes	Yes	Yes	Yes
Wall Mounting Brackets		n/a	n/a	n/a	n/a	n/a
Ceiling Mounting Bracket		n/a	n/a	n/a	n/a	n/a
Matched Outdoor Unit	RAV-	SM803AT-E	SM1103AT-E	SM1603AT-E	SM2244AT8-E	SM2804AT8-E



Application: Offices, Retail, Commercial
Mounting type: On view
Mounting height: 2200mm to 3000mm
Mounting options: Wall mounted or hanging via drop rods
Standard finish: White RAL9010 (others available upon request £poa)
Connection to: Toshiba Digital Inverter series of condensing units

Type B Curtain

		B-ES10-HP	B-ES15-HP	B-ES20-HP	B-ES25-HP	B-ES30-HP
Mounting Height (Max)	mm	3000	3000	3000	3000	3000
Length	mm	1000	1500	2000	2500	3000
Width x Height	mm	340 x 495	340 x 495	340 x 495	340 x 495	340 x 495
Heat Output (Max)	kW	8	11.2	16	22.4	28
Motor Power	kW	0.16	0.16	0.32	0.32	0.32
Starting Current	A	2	2	4	4	4
Power Supply	230v	1 Phase	1 Phase	1 Phase	1 Phase	1 Phase
Air Volume	m ³ /s	0.42	0.63	0.84	1.05	1.26
Air Volume	m ³ /h	1512	2808	3024	3780	4536
Entering Air Temp	°c	18	18	18	18	18
Air Density	kg/m ³	1.21	1.21	1.21	1.21	1.21
Temperature Difference	°c	15.7	11.9	15.7	17.6	18.4
Leaving Air Temperature	°c	33.7	29.9	33.7	35.6	36.4
Drop Rod Mounting Plate		Optional	Optional	Optional	Optional	Optional
Wall Mounting Brackets		Yes	Yes	Yes	Yes	Yes
Ceiling Mounting Bracket		n/a	n/a	n/a	n/a	n/a
Matched Outdoor Unit	RAV-	SM803AT-E	SM1103AT-E	SM1603AT-E	SM2244AT8-E	SM2804AT8-E

Coming Soon



Application: Offices, Retail, Commercial
 Mounting type: Concealed
 Mounting height: 2200mm to 4000mm
 Mounting options: Mounted in to a false ceiling
 Standard finish: White RAL9010 (others available upon request £poa)
 Connection to: Toshiba Digital Inverter series of condensing units

Type C Concealed Curtain

		C-ES10-HP	C-ES15-HP	C-ES20-HP	C-ES25-HP	C-ES30-HP
Mounting Height (Max)	mm	3000	3000	3000	3000	3000
Length	mm	1000	1500	2000	2500	3000
Width x Height	mm	1000 x 340	1000 x 340	1000 x 340	1000 x 340	1000 x 340
Heat Output (Max)	kW	8	11.2	16	22.4	28
Motor Power	kW	0.16	0.16	0.32	0.32	0.32
Starting Current	A	2	2	4	4	4
Power Supply	230v	1 Phase	1 Phase	1 Phase	1 Phase	1 Phase
Air Volume	m ³ /s	0.42	0.63	0.84	1.05	1.26
Air Volume	m ³ /h	1512	2268	3024	3780	4536
Entering Air Temp	°c	18	18	18	18	18
Air Density	kg/m ³	1.21	1.21	1.21	1.21	1.21
Temperature Difference	°c	15.7	14.7	15.7	17.6	18.4
Leaving Air Temperature	°c	33.7	32.7	33.7	35.6	36.4
Recessed Mounting		Yes	Yes	Yes	Yes	Yes
Matched Outdoor Unit	RAV-	SM803AT-E	SM1103AT-E	SM1603AT-E	SM2244AT8-E	SM2804AT8-E

Product to be launched Q4

Air Curtain Product Guide ~ Recessed Air Curtain Type C

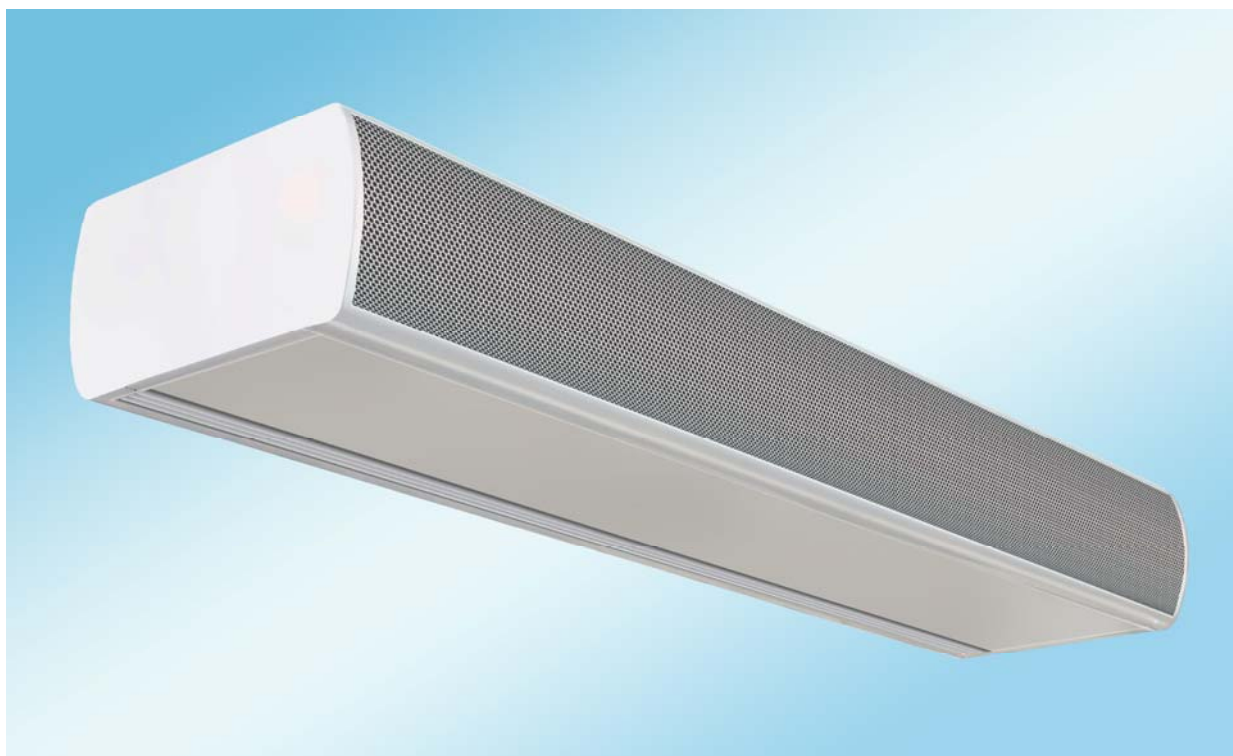

Application: Offices, Retail, Commercial
 Mounting type: On view
 Mounting height: 2200mm to 3000mm
 Mounting options: Wall Mounted, ceiling mounted or hanging via drop rods
 Standard finish: White RAL9010 (others available upon request £poa)
 Connection to: Toshiba Digital Inverter series of condensing units

Type D Curtain

		D-ES10-HP	D-ES15-HP	D-ES20-HP	D-ES25-HP	D-ES30-HP
Mounting Height (Max)	mm	3000	3000	3000	3000	3000
Length	mm	1000	1500	2000	2500	3000
Width x Height	mm	640 x 340	640 x 340	640 x 340	640 x 340	640 x 340
Heat Output (Max)	kW	8	11.2	16	22.4	28
Motor Power	kW	0.16	0.16	0.32	0.32	0.32
Starting Current	A	2	2	4	4	4
Power Supply	230v	1 Phase	1 Phase	1 Phase	1 Phase	1 Phase
Air Volume	m ³ /s	0.42	0.63	0.84	1.05	1.26
Air Volume	m ³ /h	1512	2268	3024	3780	4536
Entering Air Temp	°c	18	18	18	18	18
Air Density	kg/m ³	1.21	1.21	1.21	1.21	1.21
Temperature Difference	°c	15.7	14.7	15.7	17.6	18.4
Leaving Air Temperature	°c	33.7	32.7	33.7	35.6	36.4
Drop Rod Mounting Plate		Yes	Yes	Yes	Yes	Yes
Wall Mounting Brackets		Optional	Optional	Optional	Optional	Optional
Ceiling Mounting Bracket		Optional	Optional	Optional	Optional	Optional
Matched Outdoor Unit	RAV-	SM803AT-E	SM1103AT-E	SM1603AT-E	SM2244AT8-E	SM2804AT8-E

Type A - Air Curtain						
Air Curtain Reference	Air Curtain Length	Applicable Condenser	Heating Capacity	Remote Controller	Air Curtain Retail Price	System Retail Price
A-ES10-HP	1000mm	RAV-SM803AT-E	8 kW	RBC-AS21E2	£2,538	£3,753
A-ES15-HP	1500mm	RAV-SM1103AT-E	11.2 kW	RBC-AS21E2	£3,379	£4,919
A-ES20-HP	2000mm	RAV-SM1603AT-E	16 kW	RBC-AS21E2	£4,215	£6,325
A-ES25-HP	2500mm	RAV-SM2244AT8-E	22.4 kW	RBC-AS21E2	£5,082	£8,082
A-ES30-HP	3000mm	RAV-SM2804AT8-E	28 kW	RBC-AS21E2	£7,096	£10,246
Type B - Air Curtain						
Air Curtain Reference	Air Curtain Length	Applicable Condenser	Heating Capacity	Remote Controller	Air Curtain Retail Price	System Retail Price
B-ES10-HP	1000mm	RAV-SM803AT-E	8 kW	RBC-AS21E2	£1,671	£2,886
B-ES15-HP	1500mm	RAV-SM1103AT-E	11.2 kW	RBC-AS21E2	£2,538	£4,078
B-ES20-HP	2000mm	RAV-SM1603AT-E	16 kW	RBC-AS21E2	£3,371	£5,481
B-ES25-HP	2500mm	RAV-SM2244AT8-E	22.4 kW	RBC-AS21E2	£4,198	£7,198
B-ES30-HP	3000mm	RAV-SM2804AT8-E	28 kW	RBC-AS21E2	£5,754	£8,904
Type C - Air Curtain						
Air Curtain Reference	Air Curtain Length	Applicable Condenser	Heating Capacity	Remote Controller	Air Curtain Retail Price	System Retail Price
C-ES10-HP	1000mm	RAV-SM803AT-E	8 kW	RBC-AS21E2	£ tbc	£ tbc
C-ES15-HP	1500mm	RAV-SM1103AT-E	11.2 kW	RBC-AS21E2	£ tbc	£ tbc
C-ES20-HP	2000mm	RAV-SM1603AT-E	16 kW	RBC-AS21E2	£ tbc	£ tbc
C-ES25-HP	2500mm	RAV-SM2244AT8-E	22.4 kW	RBC-AS21E2	£ tbc	£ tbc
C-ES30-HP	3000mm	RAV-SM2804AT8-E	28 kW	RBC-AS21E2	£ tbc	£ tbc
Type D - Air Curtain						
Air Curtain Reference	Air Curtain Length	Applicable Condenser	Heating Capacity	Remote Controller	Air Curtain Retail Price	System Retail Price
D-ES10-HP	1000mm	RAV-SM803AT-E	8 kW	RBC-AS21E2	£2,368	£3,583
D-ES15-HP	1500mm	RAV-SM1103AT-E	11.2 kW	RBC-AS21E2	£3,138	£4,678
D-ES20-HP	2000mm	RAV-SM1603AT-E	16 kW	RBC-AS21E2	£3,983	£6,093
D-ES25-HP	2500mm	RAV-SM2244AT8-E	22.4 kW	RBC-AS21E2	£4,823	£7,823
D-ES30-HP	3000mm	RAV-SM2804AT8-E	28 kW	RBC-AS21E2	£6,945	£10,095

The RBC-AS21E2 remote controller
(simplified wired remote control)

All prices are quoted excluding vat at the current rate.

System price includes the Envirotec Indoor Air Curtain, the Toshiba Digital Inverter Condensing Unit c/w remote controller RBC-AS21E. Delivery period for the Air Curtains is approximately 3 weeks from date of order.

The Air Curtains come as standard in white RAL9010, however other RAL colours are available upon request and price will be based on application.

Bespoke Air Curtains are available upon request and can be manufactured to suit the individual application.

TOSHIBA
Leading Innovation >>>

Prepare to be *i*mpressed

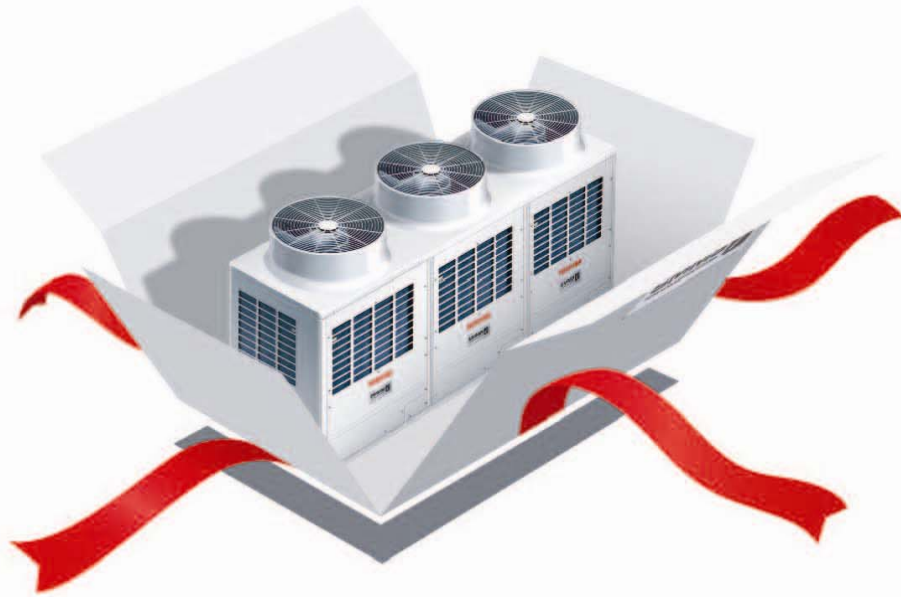

The industry first!

- High performance outdoor units with 3 compressors and 3 inverters.
- Best COP in the industry – 4.68.*
- Industry leading pipework flexibility.
- What next?...

Just one of the many industry 'firsts' we'll be unveiling when we launch the **NEW** SMMSi.

0870 8430333
marketing.uk@toshiba-ac.com
www.toshiba-aircon.co.uk

* For 8HP outdoor unit

TOSHIBA AIRCONDITIONING
Advancing the **eco**-evolution



Total Building Solutions:

From residential properties to large commercial buildings, Toshiba Air Conditioning has the solution for every type of installation. Toshiba constantly works to ensure that our air conditioners help protect the environment while delivering reassurance and reliability to our customers. With international praise for building energy-saving products the company has earned ISO 14001 certification for environmental management systems.

Residential Range:

Toshiba's range of residential products incorporates the most advanced technology for higher energy efficiency and comfort, with new air filtration systems to provide an even healthier home environment.



Light Commercial Range:

For premises such as retail, dental surgeries, doctors, education institutions and other small commercial buildings, Toshiba's range of split systems offer a wide combination of indoor units, providing greater flexibility and maximum comfort.

Commercial and Business Range:

Toshiba's range of large multi-type systems (VRF) are ideal for commercial properties, large office blocks, hospitals and hotels where there are a larger number of rooms that require a cost effective solution to varying heating and cooling.



Air to Water Heat Pump Range:

The Toshiba Estia range of Air to Water heat pumps have been specifically designed to provide heating or cooling in two separate zones as well as being able to provide domestic hot water. Ideal for providing a cost effective solution for under floor heating.

AHU Interface Solutions:

Air Handling Unit applications are easily dealt with by using the Toshiba Digital and Super Digital Inverter range of heat pumps. With no additional valves required, the installation is made very simple.



Control Systems:

Toshiba have a complete range of integrated controls systems to suit all applications to ensure a simple, yet cost effective comfortable environment.

Toshiba Carrier UK Ltd
United Technologies House
Guildford Road
Leatherhead
Surrey KT22 9UT
Tel: 01372 220240
Fax: 01372 220241

Marketing.uk@toshiba-ac.com
www.toshiba-aircon.co.uk

Distributor Stamp

Notes :

Heating output figures are based on calculations and 'general' test data. All figures are to be taken as approximations. The properties of the air curtain coils (by others) may have an affect on the performance of the outdoor units. Toshiba standard warranty is applicable to all air curtain applications. Extended warranty terms DO NOT APPLY to the products used for air curtain applications.

All data shown in this brochure is based on Toshiba Nominal Conditions :

Nominal capacities are based on Eurovent conditions :

Heating : indoor air temperature 20°C db, outdoor air temperature 7°C db

The sound pressure levels are based on : Outdoor units at 1m distance

The annual power consumption is based on 500 operating hours.

The maximum running current is based on 240V (or 400V) in the cooling mode.

The manufacturer reserves the right to change the product specifications and images without notice.

TOSHIBA AIRCONDITIONING

Advancing the **eco**-evolution